



Integration of SRF Controller in Multi Renewable Source Grid System for Stable Power Control

Kishan pal singh¹, Prof. Pavan Mehta², Prof. Laxman Solankee³

¹Research Scholar, Department of Electrical and Electronics, TIT BHOPAL (M.P.)

^{2,3}Assistant Professor, Department of Electrical and Electronics, TIT BHOPAL (M.P.)

ABSTRACT

In this paper unique approach for standalone hybrid model power generation system is been developed using MATLAB Simulink. While implementing this technique advance power control technique which used a four power sources, solar, wind, diesel generator and storage battery is demonstrated which is generally not use in commercial power system. Serious efforts has been put while completing this project for active, reactive and dump power control. For grid connected renewable energy systems the power deficit for the load will be compensated by the grid conventional power. As the powers from renewable energy resources is not constant because of environmental changes the load demand will be compensated from the utility grid during such condition. For standalone system comprising renewable source needs back up devices to ensure supply to increased power demand. In this thesis a PVA and wind farm is supported with battery energy storage system and diesel generator during increase in load demand. The modelling of the test system with and without back up sources is analyzed in MATLAB Simulink environment.

Keywords:- Dump load, Dump power control, Low cost, Standalone hybrid power generation system, Storage battery SRF control PWM Generator.

INRODUCTION

As energy requests the world over increment, the requirement for a sustainable power sources that

won't hurt nature has been expanded. A few projections show that the worldwide energy request will practically significantly increase by 2050 as in [1], Sustainable power sources currently supply somewhere close to 15% and 20% of all out world energy request. PV and Wind Energy System, WES, are the most encouraging as a future energy innovation. A 30% commitment to world energy supply from sustainable power sources by year 2020 as in would lessen the energy related CO₂ discharge by 25 %. D. Hansen et. al. [3] introduced various models for demonstrating and reenactment of remain solitary PV system with battery bank checked against a system introduced at Rise national research center. The execution has been finished utilizing Matalb/simulink. Hang-SeokChoi, introduced another zero current exchanging inverter for grid-associated PV system. The proposed circuit gives zero current changing condition to every one of the switches, which decreases exchanging losses essentially. It is controlled to extract maximum power from the sun oriented exhibit and to give sinusoidal current into the electrical utility. Gregor P. Henze, et. al [5] researched a versatile ideal control of a grid-autonomous PV system comprising of an authority, stockpiling, and a load. The control calculation depends on Q-Learning. Pedro Rosas [6] exhibited the fundamental impacts of wind power on the power system strength and power quality. It has presented additionally a total wind homestead model that help power quality and steadiness examination from huge wind ranch. Koch F., Erlich I. also, Shewarega F. [7] exhibited recreation results utilizing an agent system



containing wind power generations of up to 30%. Besides, displaying and reenactment of various sorts of wind generators incorporated into a multi-machine power system talked about. Koch F., et. al. [8] depicted the impact of huge wind stops on the recurrence of the interconnected system on which they are working. Moreover, the impact of the scene and air condition at the area of the wind unit on the output power consolidated into the reenactment. With expanded infiltration of WES different investigates for demonstrating of WTG associated with the EU proposed as in [9]-[13]. Debra J. Lew et. al [14] exhibited a structured cross breed wind/photovoltaic systems, utilizing batteries for family units in Inner Mongolia utilizing the streamlining project HOMER and model Hybrid2. R. Chedid and SaifurRahman [15] presented a choice help procedure for structure of PV/WES HEPS. The proposed PV/WES HEPS made out of four plan factors: (WTG's), PV clusters, batteries and grid-connected substations. The structure of a PV/WES HEPS dependent on political and social conditions and uses exchange off/hazard strategy. O. Omari1, et. al. [16] the DC-coupled PV/WES HEPS examined, control and the board methodologies that applied to a reproduction model of a case of this sort exhibited. Yará Najem and Méndez Hernández [17] reproduction models of the PV/WES HEPS checked with estimated information in a genuine system situated close to the division proficient energy transformation of the Kassel University. Be that as it may, the vast majority of the inquires about haven't demonstrating and reproduction of PV/Wind HEPS at the point of association of activity in subtleties. Along these lines, the goal of this paper is to present displaying, reproduction, structure and examination DC/AC converter and its controller for PV/Wind HEPS.

Age from regular sources typically utilizes capacity batteries to direct the fluctuating output. In traditional energy output acquired varies according to the common energy variety [1]. Thus, it becomes most extreme critical to avoid cheating of the batteries. To accomplish this errand dump load is included into the system, which keeps away

from the cheating of the batteries. Autonomous power age system like, PV cells has highlights like ease and basic control. In the event that we utilize a maximum power point system, which uses a diode then a power age will have comparable characteristics as that of diode[2]. On the off chance that we utilize a PV system which highlight output soundness with a numerous information dc-dc converter which is fit for controlling output power from various sources in combination[3]. There is another choice where we can go use cascaded DC-Dc converter PV system which highlight great productivity alongside minimal effort [4]. Wind turbine has best output solidness if mix of electric double layer capacitor of capacity batteries are utilized [5]. To stay away from all unique mix issues half and half strategy is created in this paper. Independent system proposed in this papers just manages the traditional energy sources and capacity battery, in outrageous case DG sets are likewise can be utilized.

DC-DC power converters are mounted toward the finish of wind and sun based power age. The mix of this two system is been finished by utilizing just a single DC-AC converter and afterward it is legitimately fed to the load. By and large it is seen that converters and capacity batteries are commonly introduced slick to the wind or sun based age systems it puts a limitation on the support and replacement. Will put a confinement, if increment load later on is considered as it might need to expand the inverter capacity. This systems are interconnected in parallel and at the output side of the inverter. In this system diesel generator is additionally been associated by utilizing a power line. Then dump load is placed on power line. Control unit appeared in figure sends ON/OFF activity directions. Individual power sources are spoken with correspondence convention, the most straightforward strategy is utilized as information to deal with is small.



II PV SYSTEM AND HYBRID POWER GENERATION SYSTEM

2.1 Types of PV Systems

Photovoltaic power systems square measure usually classified in line with their useful and operational necessities, their element configurations, and the way the instrumentation is connected to different control sources and electrical burdens. The two essential characterizations square measure matrix associated or utility-intelligent frameworks and complete systems. Electrical phenomenon systems will be designed to produce DC and/or AC electric company, will operate interconnected with or freelance of the utility grid, and might be connected with alternative energy sources and energy storage system.

Grid-connected or utility-intelligent PV frameworks are intended to work in parallel with and interconnected with the electrical utility lattice. The initial segment in framework associated PV frameworks is that the electrical converter, or power obtaining unit (PCU). The PCU changes over the DC control made by the PV exhibit into AC control in accordance with the voltage and power quality necessities of the utility lattice, and mechanically stops movement capacity to the matrix once the utility framework isn't stimulated.

A bi-directional interface is made between the PV framework AC yield circuits and furthermore the electrical utility system, for the most part at partner on-the-scene circulation board or passage. This empowers the AC control made by the PV framework to either give on-the-spot electrical burdens or to back-feed the network once the PV framework yield is greater than the one location stack request. During the evening and through elective periods once the electrical masses are bigger than the PV framework yield, the equalization of intensity required by the heaps is gotten from the electrical utility This component is required on the whole network associated PV frameworks, and guarantees that the PV framework won't proceed to work and input to the

utility matrix once the lattice is down for administration or fix.

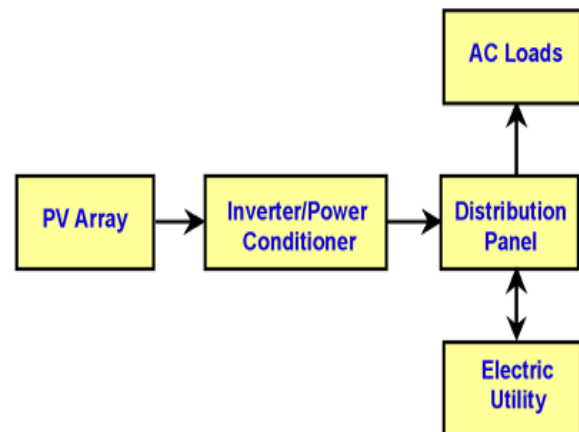

Fig 1: Diagram of grid-connected photovoltaic system.

2.2 Stand-Alone Photovoltaic Systems

Stand-Alone photovoltaic Systems complete PV systems unit designed to control freelance of the electrical utility grid, and unit generally designed and sized to provide positive DC and/or AC electrical masses. These styles of systems is additionally powered by a PV array exclusively, or may use wind, associate engine-generator or utility power as associate auxiliary power offer in what's mentioned as a PV-hybrid system. The simplest form of complete PV system may be a direct-coupled system, whenever the DC yield of a PV module or exhibit is specifically associated with a DC stack (Figure 3.4). Since there's no voltage storage (batteries) in direct-coupled frameworks, the load just works throughout daytime, creating these styles appropriate for common applications like ventilation fans, water pumps, and little circulation pumps for star thermal water warming frameworks. Coordinating the ohmic opposition of the electrical load to the most power yield of the PV exhibit may be an important a part of planning well-performing direct-coupled system. sure as shooting masses like positive-displacement water pumps, a sort of electronic DC-DC device, referred to as a most point tracker (MPPT), and is employed between the array and load to assist higher utilize the obtainable array most power output.

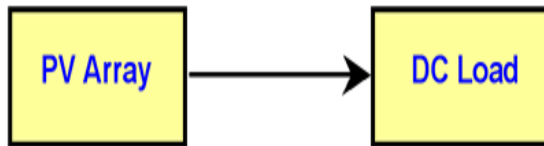

Fig 2: Direct-coupled PV system.

In several complete PV frameworks, batteries are utilized for vitality stockpiling. Below figure demonstrates an outline of a run of the mill finish PV framework fueling DC and AC loads. Figure 4 shows however a typical PV hybrid system may be designed

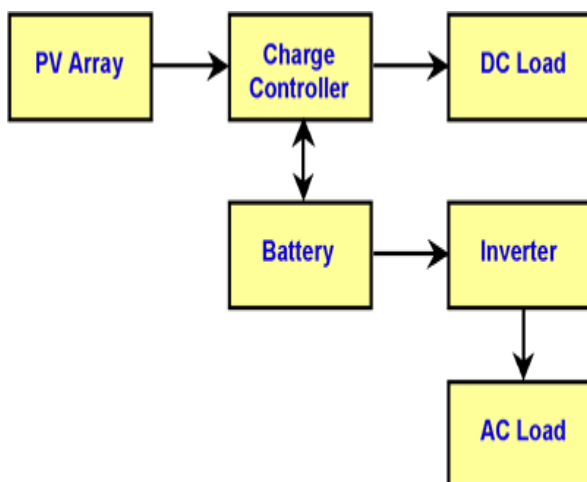

Fig 3: Diagram of stand-alone PV system with battery storage powering DC and AC loads.

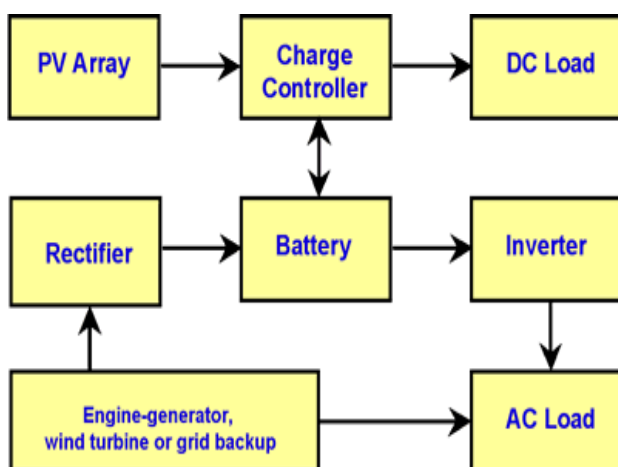

Fig 4: Diagram of photovoltaic hybrid system.

III POWER ELECTRONICS CONVERTER AND CONTROLLER

3.1 Three Phase Inverter

Inverters are used to create single or poly phase AC voltages from a DC supply. In the class of poly phase inverters, three-phase inverters are by far the largest group. A very large number of inverters are used for adjustable speed motor drives. The typical inverter for this application is a “hard-switched” voltage source inverter producing pulse-width modulated (PWM) signals with a sinusoidal fundamental. Recently researches have shown detrimental effects on the windings and the bearings resulting from unfiltered PWM waveforms and recommend the use of filters. A very common application for single-phase inverters are so-called “uninterruptable power supplies” (UPS) for computers and other critical loads. Here, the output waveforms range from square wave to almost ideal sinusoids. UPS designs are classified as either “off-line” or “online”. An off-line UPS will connect the load to the utility for most of the time and quickly switch over to the inverter if the utility fails. An online UPS will always feed the load from the inverter and switch the supply of the DC bus instead. Since the DC bus is heavily buffered with capacitors, the load sees virtually no disturbance if the power fails.

Modern inverters use insulated gate bipolar transistors (IGBTs) as the main power control devices. Besides IGBTs, power MOSFETs are also used especially for lower voltages, power ratings, and applications that require high efficiency and high switching frequency. In recent years, IGBTs, MOSFETs, and their control and protection circuitry have made remarkable progress. IGBTs are now available with voltage ratings of up to 3300 V and current ratings up to 1200 A. MOSFETs have achieved on-state resistances approaching a few milliohms. In addition to the devices, manufacturers today offer customized control circuitry that provides for electrical isolation, proper operation of the devices under normal operating conditions and protection from a variety of fault conditions. In addition, the industry provides good support for specialized passive



devices such as capacitors and mechanical components such as low inductance bus-bar assemblies to facilitate the design of reliable inverters. In addition to the aforementioned inverters, a large number of special topologies are used.

Figure 5(a) shows a three-phase inverter, which is the most commonly used topology in today's motor drives. The circuit is basically an extension of the H-bridge-style single-phase inverter, by an additional leg. The control strategy is similar to the control of the single-phase inverter, except that the reference signals for the different legs have a phase shift of 120° instead of 180° for the single-phase inverter. Due to this phase shift, the odd triplen harmonics (3rd, 9th, 15th, etc.) of the reference waveform for each leg are eliminated from the line-to-line output voltage. The even-numbered harmonics are canceled as well if the waveforms are pure AC, which is usually the case. For linear modulation, the amplitude of the output voltage is reduced with respect to the input voltage of a three-phase rectifier feeding the DC bus.

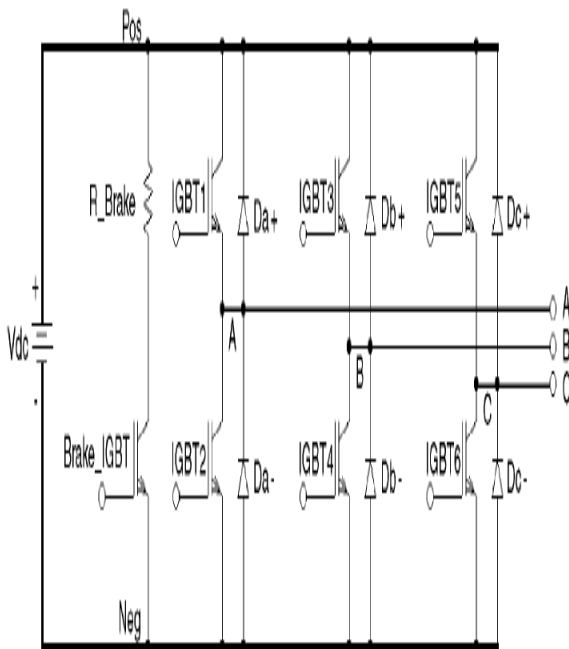

(a)

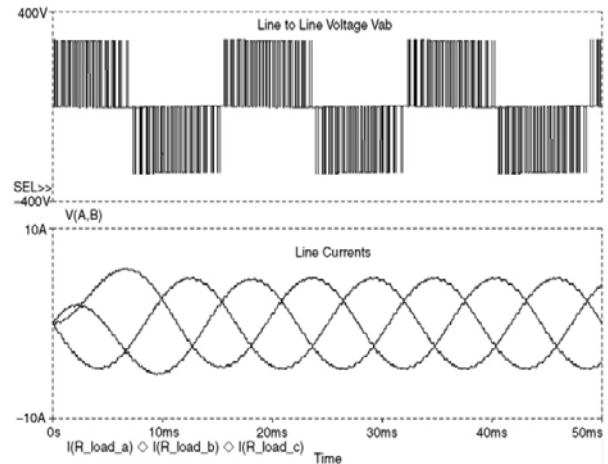

(b)

Figure 5: Operation of Three phase bridge inverter (a) circuit diagram; (b) Voltage & Current Waveform.

To compensate for this voltage reduction, the fact of the harmonics cancellation is sometimes used to boost the amplitudes of the output voltages by intentionally injecting a third harmonic component into the reference waveform of each phase leg. Figure. 4.3.(b) shows the typical output of a three-phase inverter during a startup transient into a typical motor load. This figure was created using circuit simulation. The upper graph shows the pulse-width modulated waveform between phases A and B, whereas the lower graph shows the currents in all three phases. It is obvious that the motor acts a low-pass filter for the applied PWM voltage and the current assumes the wave shape of the fundamental modulation signal with very small amounts of switching ripple.

Like the single-phase inverter based on the H-bridge topology, the inverter can deliver and accept both real and reactive power. In many cases, the DC bus is fed by a diode rectifier from the utility, which cannot pass power back to the AC input.

3.2 SAMPLING TECHNIQUE

In this method of modulation, several pulses per half-cycle are used. Instead of maintaining the width of all pulses, the width of each pulse is varied proportional to the amplitude of a sin-wave



evaluated at the centre of the same pulse. By comparing a sinusoidal reference signal with a triangular carrier wave, the gating signals are generated. The frequency of reference signal determine the inverter output frequency and its peak amplitude, controls the modulation index, M , and then in turn the RMS output voltage in Fig3 shows the more common carrier technique, the conventional sinusoidal pulse width Modulation (SPWM) technique, which is based on the principle of comparing a triangular carrier signal

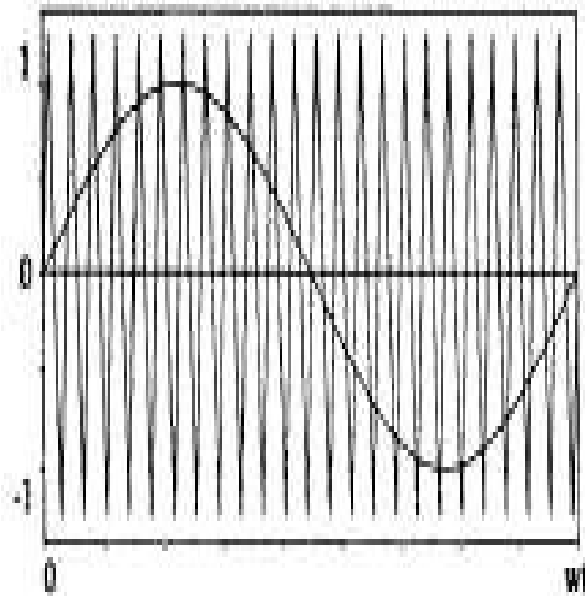

with a sinusoidal reference waveform (natural sampling). The figure below gives the sinusoidal pulse width modulation.

Figure 6: Sinusoidal pulse width modulation.

3.3 SYNCHRONOUS REFERENCE FRAME THEORY:

Since the generated voltage from renewable energy sources is DC, we need inverter for converting DC voltage to AC before connecting it to grid. Grid is a voltage source of infinite capability. The output voltage and frequency of inverter should be same as that of grid frequency and voltage. The output of grid connected inverter can be controlled as a voltage or current source and pulse width modulated (PWM) voltage source inverters (VSI) are most widely used. The three

phase full bridge inverter topology is the most widely used configuration in three phase systems. The inverter selected is current controlled voltage source inverter. IGBT's are used as the switching element which is operated at a frequency of 20 KHz. Bi-polar PWM technique is used in which switches in each pair are turned ON and OFF simultaneously and output voltage varies between $-V_s$ and $+V_s$, where V_s is the input voltage of inverter which is considered as battery as shown in figure 7 As in single-phase VSIs, the switches of any leg of the inverter (Q_1 and Q_4 , Q_3 and Q_6 , or Q_5 and Q_2) cannot be switched on simultaneously because this would result in a short circuit across the dc link voltage supply. The output of each leg depends only on input voltage and switch status and is independent of load current.

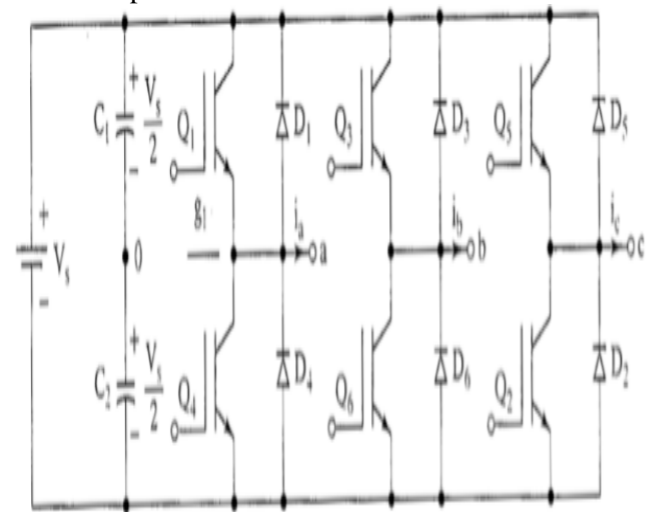

Figure 7: Three Phase Voltage Source Inverter Topology.

Transformations from a three-phase system to different two-phase systems can be used in order to avoid controlling coupled ac currents and voltages. These are based on the fact that in a balanced three-phase system there are only two independent current/voltages, thus the third current/voltage can be expressed by the other two. These systems are often referred to as reference frames, where the frame is the axis system of the transformed system



Inverter Control using Synchronous Reference Frame Technique

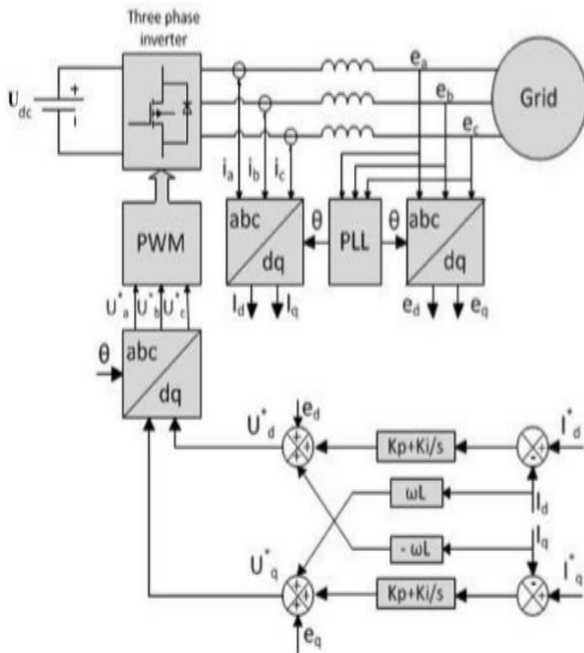

Figure 8: Block diagram of Synchronous reference frame control.

A block diagram of the Synchronous reference frame ordq control is represented in figure 4. Since the controlled current has to be in phase with the grid voltage, the phase angle used by the abc→ dq transformation module has to be extracted from the grid voltages. Phase-locked loop (PLL) technique is adopted to provide the phase information of the grid voltage, which is needed to transform the grid currents Id and Iq in the in the dq frame and then transform the voltage control signal back to the abc frame. Two PI controllers are adopted to regulate Id and Iq according to the current reference Id* and Iq*, which determines the real power and reactive power exchanged with the grid respectively. The inverter is assumed to be powered by a constant DC power source and hence no controller is needed to regulate the DC link voltage. Otherwise a controller can be introduced. The reference for the reactive current is usually set to zero, if the reactive power control is not allowed. In the case that the reactive power has to be controlled, a reactive power reference

must be imposed to the system. The dq control structure is normally associated with proportional–integral (PI) controllers since they have a satisfactory behaviour when regulating dc variables. For improving the performance of PI controller in such a structure as depicted, cross-coupling terms and voltage feed forward are usually used. These are neglected in this project work. This scheme has the particular advantage of independent control of the real and reactive power components of the grid currents, which can be directly translated into real and reactive power. As a result, it is possible to set the real and reactive power sent to the grid directly.

IV SIMULATION RESULT AND DISCUSSION

4.1 According to the contribution of solar powered and wind system are vary. So the output is likewise vary as appeared in Fig4.1

Case1 when the wind and solar system are connected without using SRF controller.

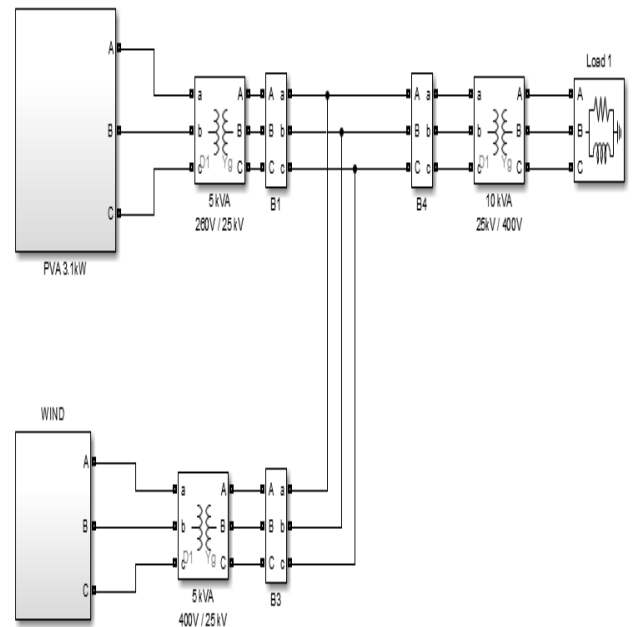

Figure 4.1: Only wind and solar system connected grid without SRF control.

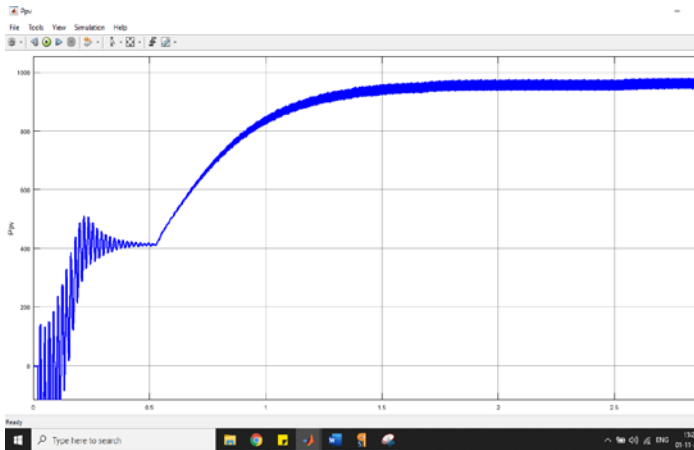

Figure 4.2: Power output from PVA without SRF control.



Figure 4.3: Power of wind farm without SRF control.

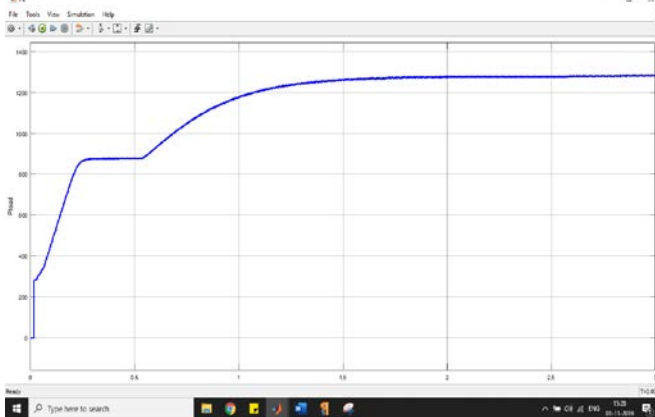

Figure 4.4: Power of load without SRF control.

Case-2 when hybrid power generation system is connected with SRF controller.

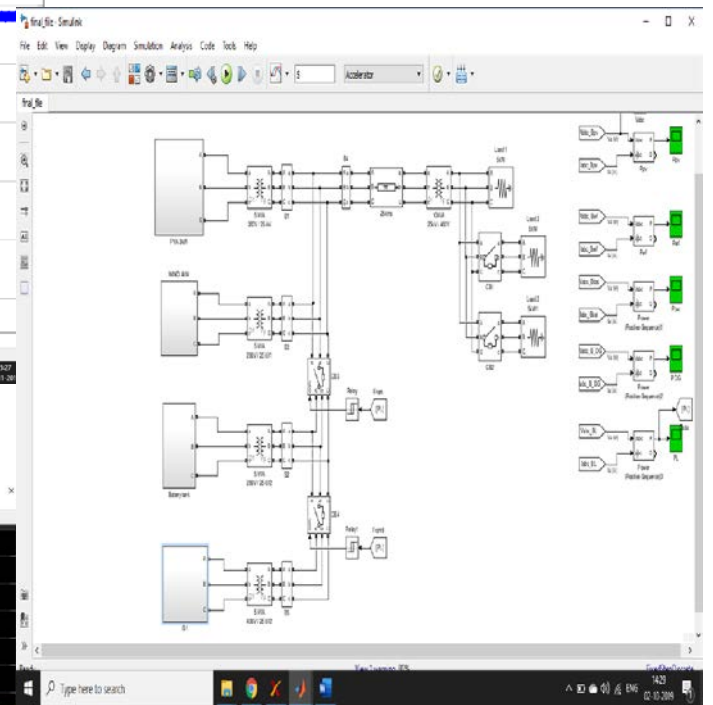

Figure 4.5: Proposed test system with battery and DG connected to grid with SRF control.

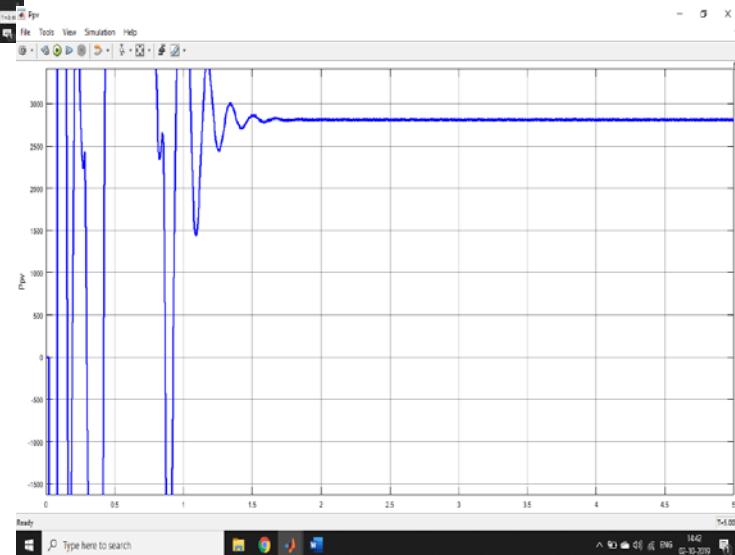

Figure 4.6: PVA power with SRF control.

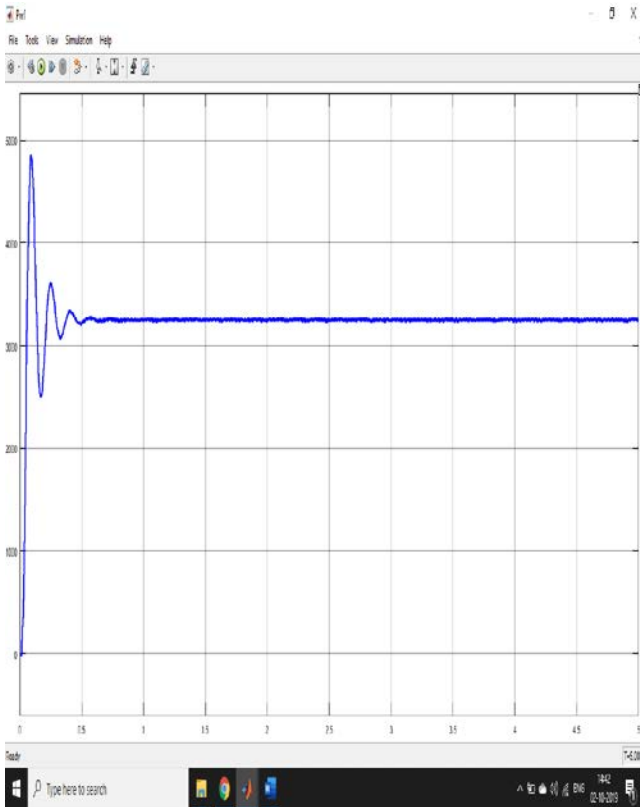

Figure 4.7: Wind farm power with SRF control.

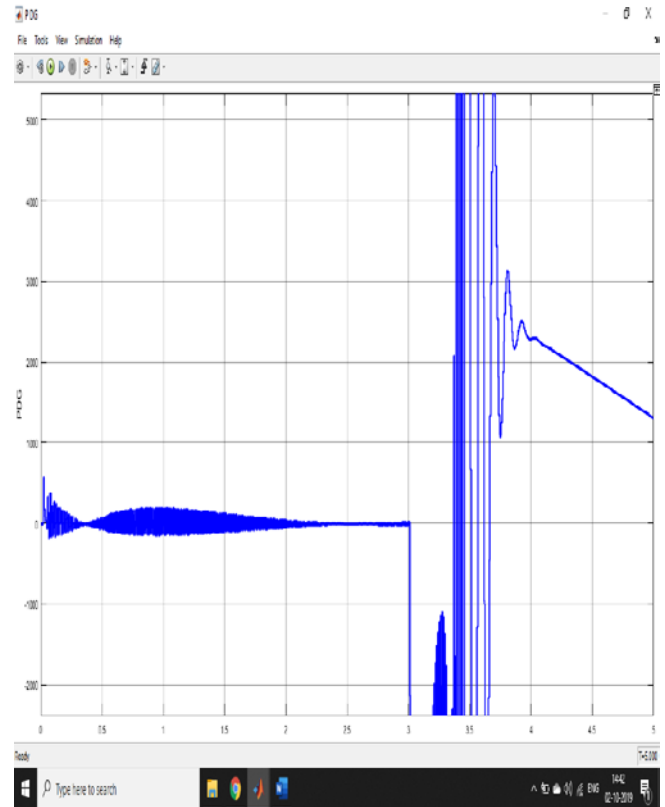

Figure 4.9: Diesel generator power with SRF control.

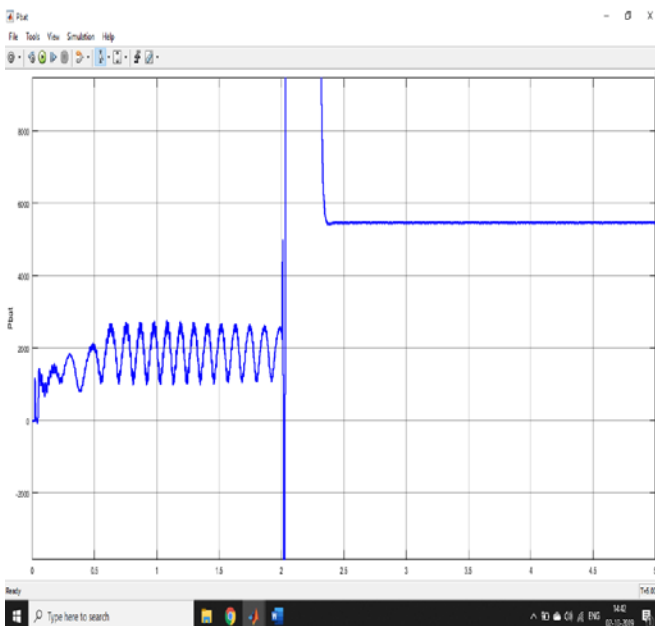

Figure 4.8: Battery power with SRF control.

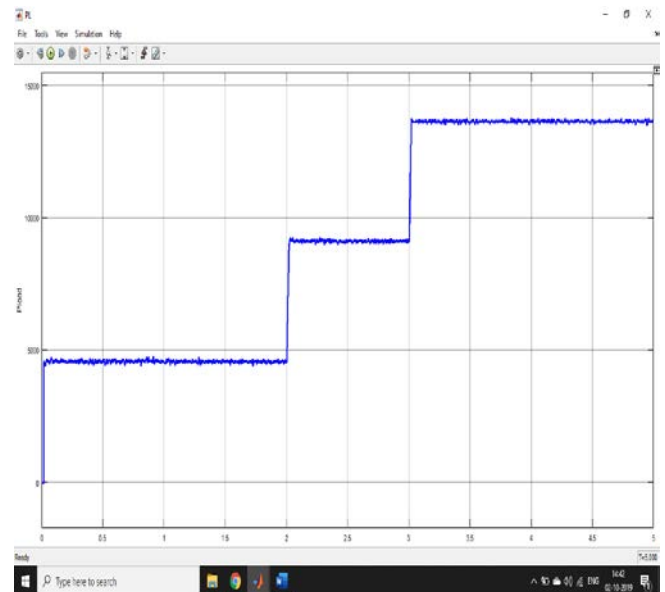

Figure 4.10: Load power demand change with respect to time.



V CONCLUSION AND FUTURE SCOPE

In this paper presents complete design and implementation of three phase grid connected inverter for renewable energy. The different types of renewable sources were studied and a hybrid energy system comprising of PV array, wind turbine ,battery and hydraulic turbine was stimulated in MATLAB/Simulink. Hybrid power generation system is providing continues power to grid. The objectives for this work have been successfully realized through analysis and simulation in MATLAB/Simulink. The effectiveness of the synchronous reference frame technique has been proved through numerous simulation results. When synchronous reference frame control is used for inverter then output will be more stable as compare to with SRF control technique. And harmonics reduction is easily possible through the srf controller.

REFERENCES:

- [1] S.-K. Kim, J.-H.Jeon, C.-H.Cho, J.-B.Ahn, and S.-H. Kwon, "Dynamic modeling and control of a grid-connected hybrid generation system with versatile power transfer," *IEEE Trans. Ind. Electron.*, vol. 55, no. 4, pp. 1677– 1688, Apr. 2008.
- [2] K. Kobayashi, H. Matsuo, and Y. Sekine, "An excellent operating point tracker of the solar-cell power supply system," *IEEE Trans. Ind. Electron.*, vol. 53, no. 2, pp. 495–499, Apr. 2006.
- [3] K. Kobayashi, H. Matsuo, and Y. Sekine, "Novel solar-cell power supply system using a multiple-input dc–dc converter," *IEEE Trans. Ind. Electron.*, vol. 53, no. 1, pp. 281–286, Feb. 2006.
- [4] A. I. Bratcu, I. Munteau, S. Bacha, D. Picault, and B. Raison, "Cascaded dc–dc converter photovoltaic systems: Power optimization issues," *IEEE Trans. Ind. Electron.*, vol. 58, no. 2, pp. 403–411, Feb. 2011.
- [5] W. Li, G. Joos, and J. Belanger, "Real-time simulation of a wind turbine generator coupled with a battery supercapacitor energy storage system," *IEEE Trans. Ind. Electron.*, vol. 57, no. 4, pp. 1137–1145, Apr. 2010.
- [6] F. Valenciaga and P. F. Puleston, "Supervisor control for a stand-alone hybrid generation system using wind and photovoltaic energy," *IEEE Trans. Energy Convers.*, vol. 20, no. 2, pp. 398–405, Jun. 2005.
- [7] S. Meenakshi, K. Rajambal, C. Chellamuthu, and S. Elangovan, "Intelligent controller for a stand-alone hybrid generation system," in *Proc. IEEE Power India Conf.*, New Delhi, India, 2006.
- [8] R. Belfkira, O. Hajji, C. Nichita, and G. Barakat, "Optimal sizing of stand-alone hybrid wind/pv system with battery storage," in *Proc. PowerElectron. Appl. Eur. Conf.*, Sep. 2007, pp. 1–10.
- [9] S. Wang and Z. Qi, "Coordination control of energy management for stand-alone wind/pv hybrid systems," in *Proc. IEEE ICIEA*, May 2009, pp. 3240–3244.
- [10] C. Liu, K. T. Chau, and X. Zhang, "An efficient wind-photovoltaic hybrid generation system using doubly excited permanent- magnet brushless machine," *IEEE Trans. Ind. Electron.*, vol. 57, no. 3, pp. 831–839, Mar. 2010.
- [11] F. Bonanno, A. Consoli, S. Lombardo, and A. Raciti, "A logistical model for performance evaluations of hybrid generation systems," *IEEE Trans. Ind. Appl.*, vol. 34, no. 6, pp. 1397–1403, Nov./Dec. 1998.
- [12] M. H. Nehrir, B. J. LaMeres, G. Venkataramanan, V. Gerez, and L. A. Alvarado, "An approach to evaluate the general performance of stand-alone wind/photovoltaic generating systems," *IEEE Trans. Energy Convers.*, vol. 15, no. 4, pp. 433–439, Dec. 2000.
- [13] J. M. Carrasco, L. G. Franquelo, J. T. Bialasiewicz, E. Galvan, R. C. P. Guisado, M. A. M. Prats, J. I. Leon, and N. Moreno-Alfonso, "Power-electronic systems for the grid integration of renewable energy sources: A survey," *IEEE Trans. Ind. Electron.*, vol. 53, no. 4, pp. 1002–1016, Jun. 2006.
- [14] S. Jiao, G. Hunter, V. Ramsden, and D. Patterson, "Control system design for a 20 kW wind turbine generator with a boost converter and battery bank load," in *Proc. PESC*, Sep./Oct. 2001, pp. 2203–2206.
- [15] S. Tanezaki, T. Matsushima, and S. Muroyama, "Stand-alone hybrid power supply



system composed of wind turbines and photovoltaic

modules for powering radio relay stations,” in Proc. IEEE INTELEC, Oct. 2003, pp. 457–462.

[16] A. M. O. Haruni, A. Gargoom, M. E. Haque, and M. Negnevitsky, “Dynamic operation and control of a hybrid wind-diesel stand alone power systems,” in Proc. IEEE APEC, Feb. 2010, pp. 162–169.

[17] D. B. Nelson, M. H. Nehrir, and C. Wang, “Unit sizing of stand-alone hybrid wind/pv/fuel cell power generation systems,” in Proc. IEEE Power Eng. General Soc. Meeting, Jun. 2005, vol. 3, pp. 2116–2122.

[18] M. C. Chandorkar, D. M. Divan, and R. Adapa, “Control of parallel connected inverters in standalone ac supply systems,” IEEE Trans. Ind. Appl., vol. 29, no. 1, pp. 136–143, Jan./Feb. 1993.

[19] J. M. Guerrero, J. Matas, L. G. de Vicuna, M. Castilla, and J. Miret, “Wireless-control strategy for parallel operation of distributed-generation inverters,” IEEE Trans. Ind. Electron., vol. 53, no. 5, pp. 1461–1470, Oct. 2006.